Chapter 6

Evaluation of the power supply design

Abstract

In this chapter, the design work developed previously in Chapter 4 is being verified through an experimental setup. Tests over the available setups are performed, and results are presented.

6.1. Introduction	Page 126
6.2. MCU measurements	Page 126
6.3. Battery protection verification	Page 130
6.4. Summary	Page 132

6.1. Introduction

The goal of this chapter is to verify the design of the power supply, previously described in Chapter 4. It has been decided to realize separate PCB boards for each module of the entire power supply, and to evaluate each separately. The experimental setups are described, and the results available at the moment are shown.

Note that, for practical reasons, detailed in the summary, not all the proposed measurements could be performed.

6.2. MCU measurements

In this section, the methods and results of measurement and testing of the MCU module are described.

The first test consists only of testing of MCU's clock. The result was achieved at pin OSC2 (pin 14) and the waveform acquired from the oscilloscope can be seen in figure 6.1.

The output frequency on this pin is four times lower than inner clock frequency. From figure may be observed that time period is approximately $1\mu\text{s}$, what means a frequency of 1MHz respectively oscillator frequency is 4Mz.

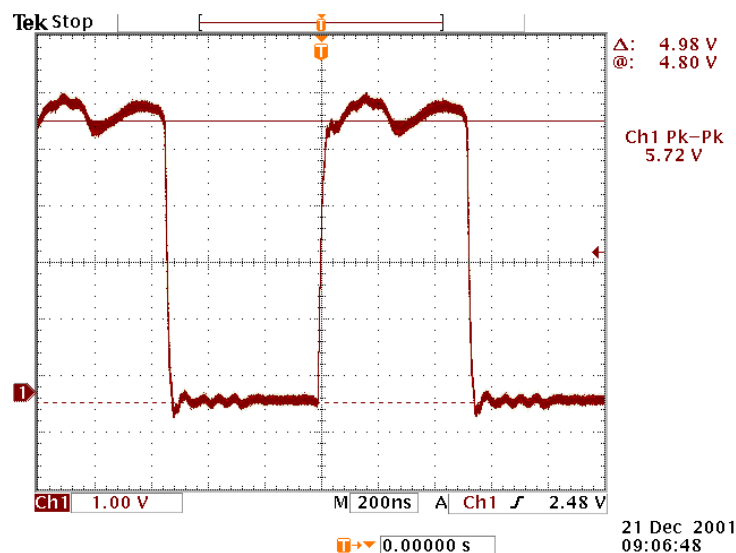

Figure 6.1 Oscillator waveform

Evaluation of protections

The scheme of the test circuit is depicted in figure 6.2. For the real measurement setup it was used a logical analyzer instead of light-emitting diodes, but diodes are in the figure for better understandability, because only two states were measured: high state (diode glows) and low state (diode not glows).

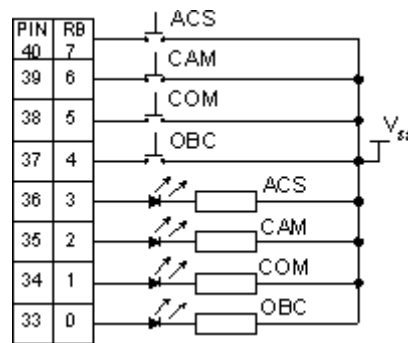

Figure 6.2 Simplified scheme of connection for testing protections

Protections for ACS, COM and CAM

These protection should work only as a turn-off: after NOT_FAULT signal switch to low level (logic 0) appropriate ENABLE signal must switch to low level too, but if the NOT_FAULT signal will switch to high level afterwards, ENABLE signal must stay on low level, because user can be turn-on only after command from OBC via I²C bus. These functions were tested for all protections with positive function.

Protection for OBC

Protection for OBC works same way as the rest of the protections, the only difference is that the OBC cannot be turned on by itself and PSU must provide the turn-on signal.

This protection was tested in the same way as the other protections; only the time between turn off/on signals was measured. Because OBC can be turn-off also when watchdog overflow, time for this overflow was measured too. Result was that OBC was turned off after app. 12 seconds and turned on again after app. 5.5 minutes, these times are sufficient for it's purpose, because there is no request for precise times. Assignment was to have times around 10 seconds and 5 minutes and these times were achieved.

Testing of AD converter

For testing if A/D converter works well had been written special software, which write bytes from memory to output pins, for easier code was used port C for this output (see figure 6.3a). Because some pins from this port is used for another function (I²C, bootpin etc.) rest of program had to be changed too. To select which byte from memory will be on output was decided to use four input pins on port D (figure 6.3b).

As a result 16 different bytes from memory could be read. AD converter was connected to the variable voltage source and from port C was read value of higher and lower byte. From them were extracted 12bit final value and this value was recalculated from equation:

$$V = \frac{V_{ref}}{2^{res}} \cdot N$$

where V_{ref} is the reference voltage for AD converter (5V),

res is resolution of the ADC (12bit) and

N is the value from memory converted from binary to decimal format; result is in volts.

In Table 6.1 are shown some tested values. All results remain under 1% error and it is concluded that this error is acceptable.

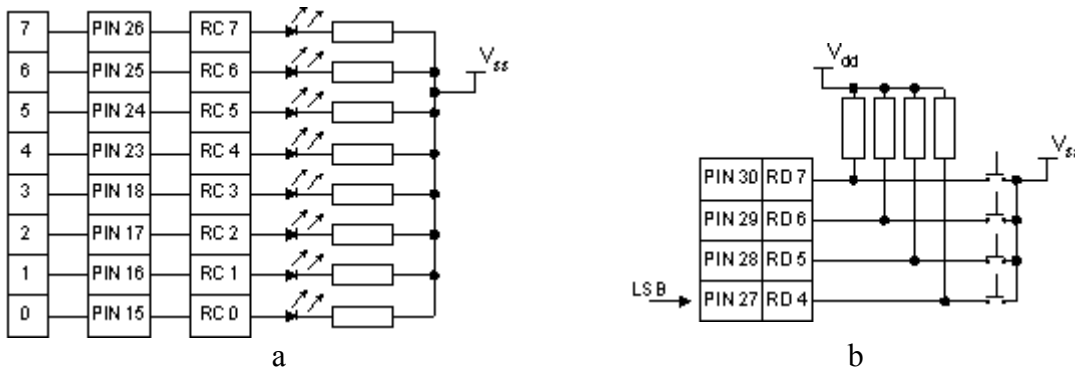

Figure 6.3 Simplified scheme of connection for reading memory (a) and scheme of byte selector (b)

Voltage on source (Multimeter)	Higher byte bit format	Lower byte bit format	Final number from ADC	Recalculated voltage	Difference
1.4720V	100	10110111	1207	1.47339V	1.4mV
2.990V	1001	10010100	2452	2.99316V	3.2mV
0.521V	1	10101001	425	0.5187V	2.2mV

Table 6.1 Measured values

Next test is about control signals for multiplexers, these signals are on port D, pins 19-22. During one reading period, these control signals must produce numbers from 0 to 15. These pins were connected to the logic analyzer and result is shown in the figure 6.4, where is clear that each

pin switching from 0 to 1 with half frequency then the previous one. That means that all combinations occur and multiplexer switches to each input signal.

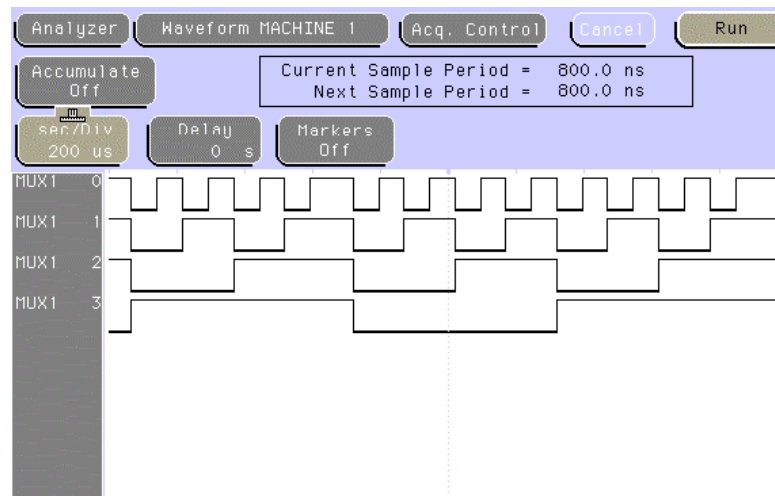

Figure 6.4 Signals for driving multiplexers

Last test is nearly the same as the tests above; only change is that on PORTC will be 8-bit value from temperature sensor in degrees of Celsius. First temperature sensors were substituted with voltage source and whole temperature resolution was tested. Second real thermal sensor LM19 was connected and it was measured that temperature in laboratory was 21°C.

4. PWM signal testing

This test was done to be sure about PWM capability of the processor and to test low-pass filter on the end of the PWM. Both signals: PWM and analog one were measured with oscilloscope and result is shown in the figure 6.5. Frequency of the PWM signal is 7174Hz, compare to expected 7.3kHz, but this error is neglectable and was caused by binary rounding of the processor. Duty cycle was set to 30% because it is theoretically 1.5 volts and it is the maximum value for the MPPT converter. Real measured signal is smaller than expected 1.5volts, because amplitude of the PWM signal is not exact 5 volts and because of the voltage drop on the resistor. Measured waveforms are on the figure 6.5

5. I²C communication test

Test on the I²C bus must be performed on special testing facility with simulated master processor, this facility is now developing in CDH Cubesat group, after they finish the station, tests will be perform. Only tests in simulator on PC were done, but the simulator from MPLAB software has no utility for testing serial communication and these tests are not too evidential to say that software is working right.

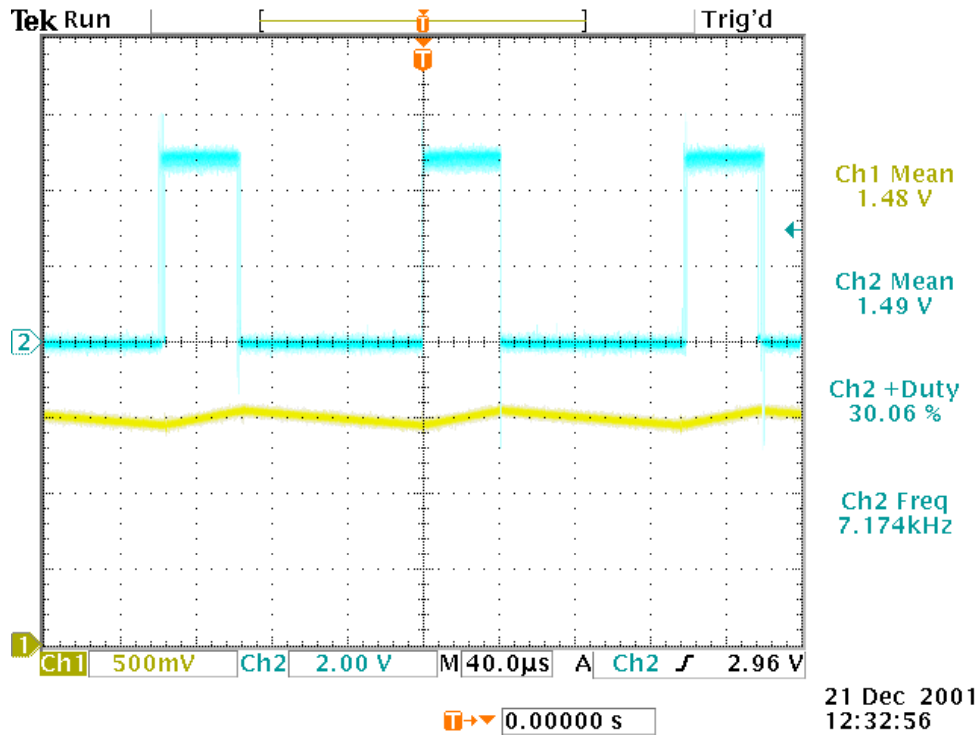

Figure 6.5 PWM signals test

6. Power consumption

During all tests current flowing to the microcontroller was measured and maximum value, when all peripherals were in use, was 3mA, what means 15mW. That is comparable to values in datasheet, where are values between 2.5mA and 5mA.

6.3. Battery protection verification

This section presents experimental results about behavior of the batteries at charging and discharging at normal room temperature.

6.3.1. Charging characteristic

In the experimental setup, a protection circuit for batteries UCC3911 has been used, and a string of two batteries have been tested.

Conditions:

- charging current: 460mA (half of capacity)

- charging voltage: constant
- charging time: approx. 100 min, until the protection circuit acts.

The protection circuit will disconnect the batteries when the voltage level will rise above the established limit: 8.45V.

In table 6.2, are presented the measured values, and the plotted charging characteristic is shown in figure 6.6.

Time [min]	0	1	2	3	4	5	6	7	8	9	10	12	15	20	25
Voltage[V]	5.83	6.97	7.1	7.35	7.42	7.42	7.5	7.55	7.59	7.62	7.64	7.67	7.69	7.74	7.79
Time [min]	30	35	40	45	50	55	60	65	70	75	80	85	90	95	100
Voltage[V]	7.82	7.83	7.85	7.87	7.89	7.91	7.94	7.97	8.02	8.05	8.1	8.15	8.2	8.27	8.35

Table 6.2 Measured voltage values for charging of batteries

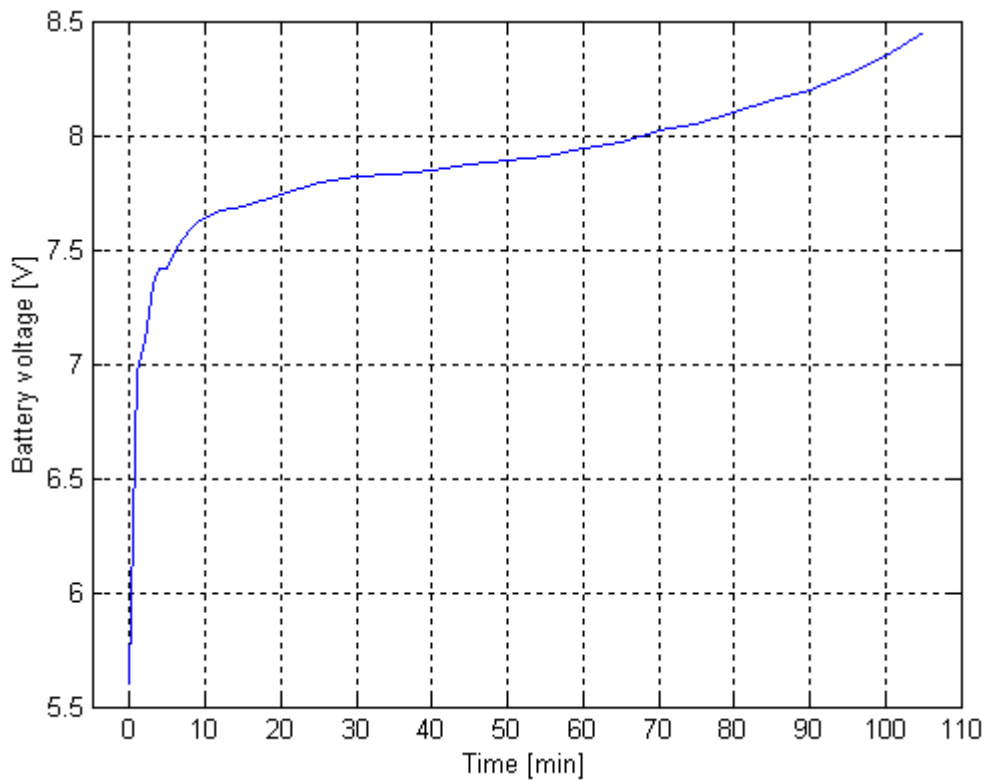

Figure 6.6 Experimental charging characteristic for the batteries

6.3.2. Discharging characteristic

The conditions for discharging batteries test are the same as for the previous performed test, for charging batteries. In table 6.3 are shown the measured values and figure 6.7 presents the discharging characteristic.

Time [min]	0	1	2	3	4	5	6	7	8	9	10	12	15	20	25
Voltage[V]	8.45	8.44	8.07	8.03	7.97	7.85	7.82	7.8	7.78	7.77	7.75	7.73	7.68	7.6	7.56
Time [min]	30	35	40	45	50	55	60	65	70	75	80	85	90	95	100
Voltage[V]	7.53	7.5	7.46	7.43	7.38	7.36	7.31	7.27	7.24	7.22	7.19	7.17	7.13	7.06	6.74

Table 6.3 Measured voltage values for discharging of batteries

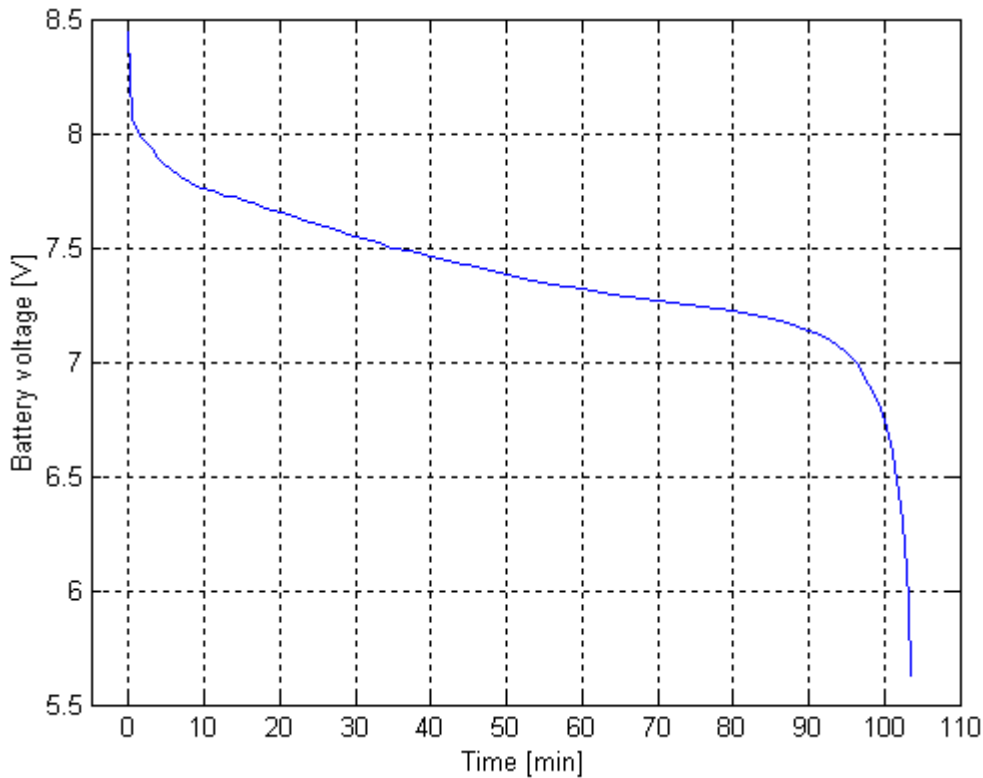

Figure 6.7 Experimental discharging characteristic for the batteries

There are a few points after $t = 100$ min, unregistered in the table, but visible in the figure. The protection circuit disconnects the batteries at $V = 6.09V$.

6.4. Summary

Experimental results are captured and shown in this chapter.

As written in the introduction, there were several reasons for not performing all the necessary tests at the time of delivering the report. One of the strongest reasons has been lack of components, due to long delivery time from the manufacturers. Due to constraints about mass and dimensions of the power supply board, all the electronic components have been chosen in respect

with reliability (brand-name, well-known manufacturers), small outline packages and high-efficiency. This led to some delays in practical implementation of the designed board. One result is that it has been decided to realize separate PCBs for each module of the power supply and to test them independently, further connections between modules being easy to be done later.

All possible tests, available at this time, were performed on microcontroller and the results obtained are satisfying the demands for the software and hardware. Tests of the communication with OBC must be performed later after testing facility will be prepared. Also tests on real solar cells must be done to test the digital version of MPPT control signal.

The tests performed over the battery protection circuit shown that this device is working properly, implementing an efficient overcharging and overdischarging protection, as expected from the analysis performed in section 4.3. Charging and discharging characteristic for a string of two batteries are depicted in section 6.3.